

White Paper

Ergotron® Desk Stands

DESIGN OF AN ERGONOMICALLY CORRECT DESK STAND FOR FLAT PANEL MONITORS



DESIGN OF AN ERGONOMICALLY CORRECT DESK STAND FOR FLAT PANEL MONITORS

Presented by Ergotron, Inc.

Abstract

Now for the first time flat panel monitor users can obtain low cost, ergonomically correct, vertically adjustable stands to address the full range of users, from children to adults, in the traditional seated work environment.

Available Technology

Ergotron, Inc., the world's leading supplier of flat panel mounting equipment, has just introduced its Neo-Flex™ LCD Stand. This product is the world's first field adjustable, ergonomically correct flat panel monitor desk stand. The Neo-Flex™ Stand can be used to provide ergonomic adjustability for the estimated 70 million flat panel monitors currently installed that do not have ergonomic adjustability or it can be utilized to upgrade new monitors that do not provide this capability.

This paper was prepared to assist flat panel monitor users in applying this technology to their monitor systems and to assist users in understanding the scientific ergonomic and anthropometric principles upon which the Neo-Flex™ Stand, by Ergotron, was designed.

Note: Before reading further, it is recommended that you study the Application Notes and Technical Specifications sections on pages 13 – 14 of this document to determine if your monitor or the monitor you are contemplating buying is compatible with the stand's design specifications.

The Science of Ergonomics

Ergonomics: *Application of scientific knowledge to the work place in an effort to improve the well being and efficiency of workers.*

“The future...depends on how we develop human interfaces that create a match between the internal rhythms of the operator and the computer.”

– Dr. Joel Orr, Computer Graphics Consultant –

Background

Over the past several years numerous scientific papers have been written on the ergonomic factors involved in computer workstation design. This paper will not attempt to duplicate the large base of scientific knowledge and the many ergonomic studies already well documented. The goal of this paper is to offer a practical guide to interpreting published ergonomic guidelines and the anthropometric data that can be used to create a user friendly, ergonomically correct computer work environment.

Many factors are involved in the design of a computer workstation such as:

- **Monitor display adjustability**
- **Keyboard placement/adjustability**
- **Chair design/adjustability**
- Worksurface adjustability
- Foot rests
- Wrist rests
- Glare screens
- Lighting, task lighting
- Ease of adjustability
- Accessibility to components
- Human Computer Interfaces (HCI's)
- Space savings

All of the above issues concern themselves with the reduction or elimination of a class of physical disorders associated with poor ergonomic design known as Musculo-skeletal Stress Disorders (MSDs), which result in:

- Eye, neck and back strain
- Fatigue, headaches
- Wrist, hand, elbow and shoulder diseases
 - Carpal Tunnel Syndrome
 - Tenosynovitis
 - Tendonitis
 - Synovitis

Some of the primary causes of eye, neck and back strain, which cause visual problems and wrist, hand, elbow and shoulder diseases are:

- Improper display screen height and the inability to adjust the screen height to individual preferences throughout the work day
- Improper display screen viewing distance and the inability to adjust the same
- Improper display screen viewing angle and the difficulty of adjusting the viewing angle especially of larger monitors

A user survey conducted several years ago indicated that monitor positioning was a prime factor in assuring a computer operator's comfort. The results of that survey are shown below:

<u>Survey Questions</u>	Response	
	<u>Yes</u>	<u>No</u>
Is a height adjustable screen useful?	97%	3%
Should the screen distance be adjustable?	97%	3%
Should the inclination (tilting) of the screen be adjustable?	92%	8%

Because of the key role played by the monitor screen, this paper will focus on the relevant anthropometric data dealing with various classes of operators and the application of a series of scientifically sound ergonomic rules to determine suggested mounting heights, appropriate adjustment ranges and the adjustment moving forces required to provide an optimum human interface for flat panel monitor users. See Appendices A and B.

Ergonomic Ground Rules

The recommended mounting heights, the range of adjustability required to provide comfortable use by a range of operators, and the forces required for making adjustments to the monitor that are shown in this paper are based upon the following ergonomic ground rules gleaned from the available scientific literature and published standards on this subject. See Appendices A and B.

Screen Height

The recommended screen height for display monitors (except in special circumstances such as bifocal use) is that the top of the monitor screen should be set at or slightly below (approximately 25 mm [1"]) the eye height of the user when the user is sitting or standing in a comfortable, relaxed position. This will place the center of the screen at the ideal 15° to 20° below eye height for most desktop monitors. The screen height should be easily adjustable to accommodate gender height differences and the operator's personal preferences throughout the day. Further, the viewing height should allow the operator to view the monitor screen within an orthopedically correct "viewing cone" to minimize musculo-skeletal stress disorders (MSD's). See Appendix A.

Screen Tilt

Ideally an upward tilt with the bottom of the screen tilted toward the operator provides optimum viewing because it provides a consistent focal length when scanning from the top of the screen to the bottom. A tilt range of -5° to +30° is usually adequate depending upon the size of the monitor. **Note:** When upward tilt is used, special care must be taken to minimize screen glare.

Screen Distance from Operator

Normally the monitor screen should be placed as far away as possible from the operator, consistent with the ability to read the information presented on the screen. (The normal focal length for most people exceeds 762 mm (30") or greater, however, from a practical standpoint a recommended viewing distance from 457 mm (18") to 710 mm (28") is mentioned by several ergonomic standards.) A good rule of thumb for most installations is that the monitor screen should be placed at arms length, with the ability to move the monitor back and forth to suit individual needs being the ideal. Vertical adjustments should not result in a change in focal length.

Screen Adjustment Forces

The moving force to make any adjustment to the monitor, vertical position, tilt, pan or portrait/landscape rotation should not exceed 2.32 kg (5.1 lbs). See Table 3 and Fig. 2.

Keyboard Height/Positioning

Keyboards should be placed at a height that allows the operator to operate the keyboard with the forearms level and hands sloping slightly downward. A negatively tilting keyboard, allowing the operator to “keep the wrinkles out of the top of the wrists” is ideal. Fore and aft positioning of the keyboard should be consistent with allowing the hands to move easily over the keyboard with forearms level and elbows at the sides, maintaining a 90° - 120° angle between upper and lower arms. See Appendix B.

If the top of the monitor screen is set 25 mm (1") below the operator’s eye height as recommended, then the central row of the keyboard should be positioned 50.8 cm (20") below the top of the monitor screen for the **average** range of users.

Anthropometric Data* Utilized in the Design of Computer Workstations

Figure 1 – Visual Representation of Anthropometric Height Ranges

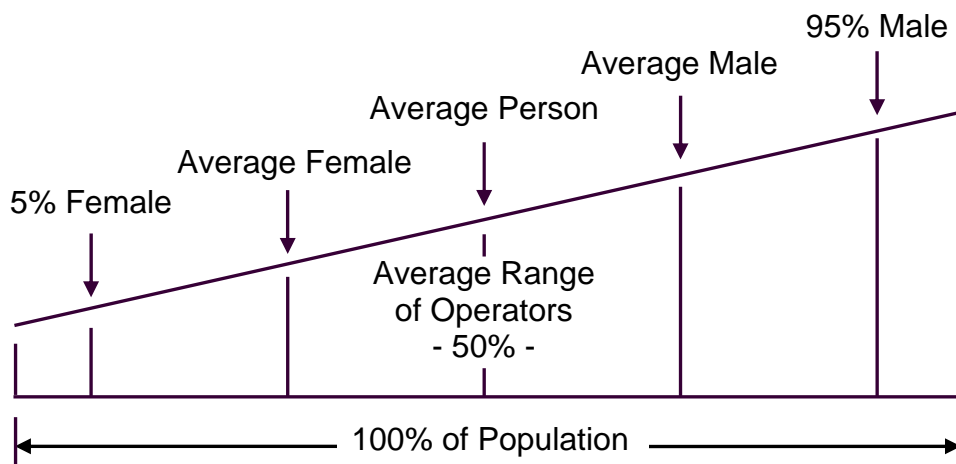

* The science of human body measurement

Copyright Ergotron, Inc., 2004, all rights reserved

Revised: December 1, 2004

Page 4



Table 1 – Anthropometric Data* for **Average** Range of Operators

	Eye Height					
	Inches			Millimeters		
	Stand	Sit	Variance**	Stand	Sit	Variance
Av. Female	59.4	44.0	3	1509	1118	391
Av. Person	61.7	46.1	15.6	1567	1171	396
Av. Male	64.4	48.5	15.9	1636	1232	404
Variance F/M	5.0	4.5	1	127	114	1

Note 1

- Eye height variance** for the average range of male to female operators
- Design criteria used for design of a 130 mm (5.1") vertically adjustable flat panel monitor desk stand. **Note:** Adjustment range extended from 114 mm (4.5") to 130 mm (5.1") to accommodate both U.S. and European populations.

Note 2

- Eye height to eye height variance for the average standing to sitting **person**
- Ideal mounting height for fixed height workstation components that must interface to a range of operators
- Design height adjustment range for a minimum height adjustable screen/ keyboard sit-stand workstation

Note 3

- Eye height variances for the average standing male to the average sitting female
- Design height adjustment range for a sit-stand workstation designed to accommodate the average range of male and female operators – 518 mm (20.4")

* Based on Anthropometric Surveys of U.S. population

** As used in this paper, the term "variance" means "difference" or "range."

Table 2 – Anthropometric Data for 5% Female to 95% Male Range of Operators

	Eye Height					
	Inches			Millimeters		
	Stand	Sit	Variance	Stand	Sit	Variance
5% Female	55.7	40.8	2	1415	1036	2
95% Male	68.6	52.1	16.5	1742	1323	419
Variance	12.9	11.3	1	328	287	1

Note 1

- Eye height variance for the 5% female to 95% male operator
- Ideal eye height adjustment range for a broad range of multi-user applications
- Design criteria used for design of 305 mm (12") or greater vertically adjustable flat panel monitor desk stand or wall mount system computer workstation.

Note 2

- Eye height variance for the 5% sitting female to the 95% standing male
- This data indicates that to design a sit-stand workstation to address the 5% to 95% range of female to male operators would require 706 mm (27.8") of vertical adjustability

Required Forces for Height and Tilt Adjustments

In order to prevent excessive straining and discomfort in joints, the required force for the adjustment of the stand should also be within acceptable limits. Table 3 shows the allowable force that can be applied by a reaching arm within ergonomic limits.

Table 3 – Ergonomically Acceptable Adjustment Forces*

	LIFT				PRESS			
	Left		Right		Left		Right	
	(lbs)	(kg)	(lbs)	(kg)	(lbs)	(kg)	(lbs)	(kg)
Male (age 30)	9.00	4.10	14.00	6.36	13.00	5.91	17.00	7.73
Female (age 30)	6.00	2.72	9.34	4.25	8.67	3.94	11.34	5.15
Male (age 50)	7.65	3.48	11.90	5.41	11.05	5.02	14.45	6.57
Female (age 50)	5.10	2.32	7.94	3.61	7.37	3.35	9.64	4.38

* Source: US Military Standard (MIL STD) 1472F



The level of force not only depends on age but also it varies depending on the gender and the arm used (i.e., left or right). An ergonomically correct desk stand must be designed such that the adjustment force must be less than 2.32 kg (5.10 lbs), which is the force that can be applied by the left arm of a 50 year old woman (Table 3).

Most of the existing lift mechanisms used in desk stands utilize spring energy to counterbalance the weight of the monitor. However, the force that is exerted by a spring increases in proportion to the displacement (Figure 2). Therefore, the 2.32 kg (5.10 lbs) limit is usually reached at small travels, thus limiting the amount of lift that can be provided in a desk stand. In order to reach an ergonomically correct amount of travel (i.e., 130 mm [5.1"], Table 1) a constant force mechanism is needed to convert the rising force of a low-cost spring into a linear force/energy device (Figure 2).

Tilting of the monitor upward may also require an excessive amount of force from the user since the torque required to tilt the monitor up will work against the weight of the monitor. Therefore, an energy pivot provided within the desk stand design will balance the weight of the monitor and assist the user during the tilt.

Figure 2 – Desk Stand Adjustment Forces Illustrated

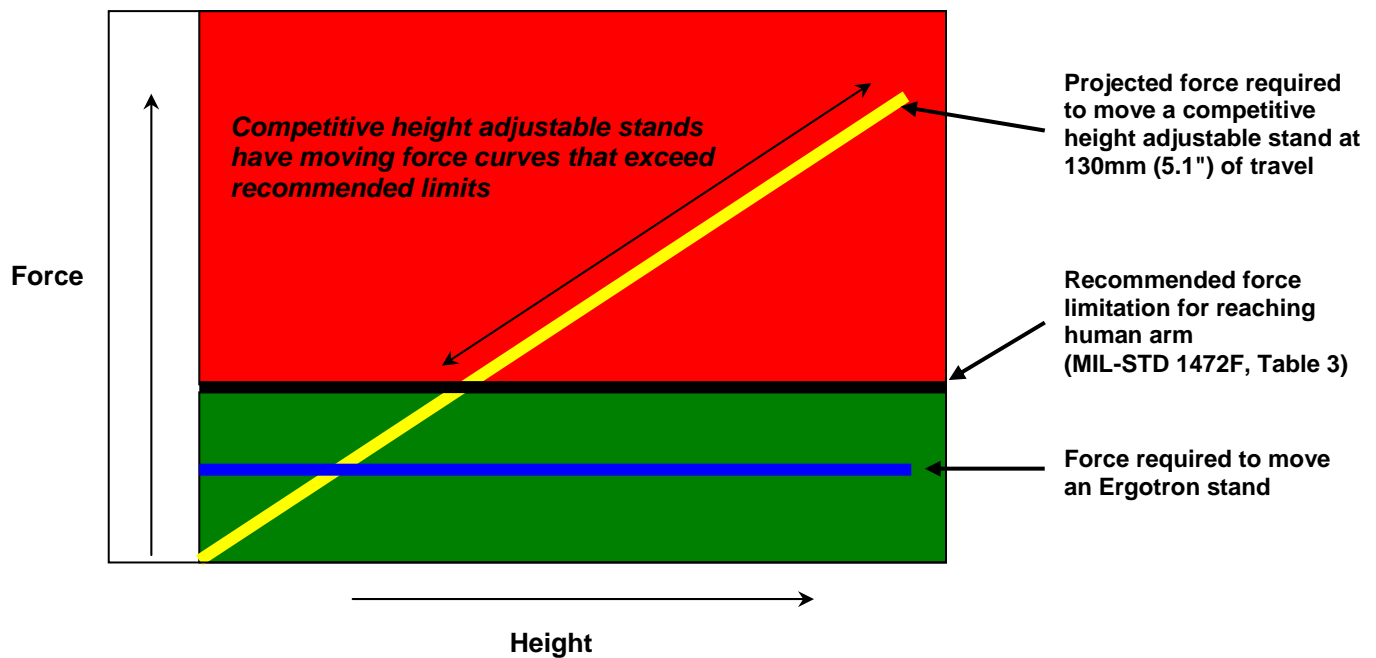

Design of an Ergonomically Correct Desk Stand for the Average Range of Male and Female Operators

A desk stand that provides full ergonomic adjustability must possess all the features explained above including height, tilt, swivel, and distance adjustments with optional portrait/landscape orientation. These adjustments must provide full ergonomic range while the adjustment forces must be within acceptable limits throughout the entire adjustment range. These features can be achieved at an acceptable cost by means of a telescoping desk stand, which utilizes a constant force mechanism (Figure 3).

Ergonomic height settings of flat panel monitors in both Portrait and Landscape orientations are shown in Figures 4 and 5 below. The center of mass implementation of the current VESA® Flat Display Mounting Interface (FDMI™) Standard has been the key factor in the proliferation of adjustable desk stands and portrait/landscape applications among FPM users.

To provide easy adjustment, a positive tactile feel and a stable work platform, all adjustments provided by the Neo-Flex™ Stand, by Ergotron, (lift, tilt, pan and portrait/landscape) are engineered to provide a typical 1.5 kg (3.3 lbs) moving force.

In all cases the stand will be designed to comply with UL Specification #60950, or to other tip test specifications supplied by the monitor manufacturer.

Figure 3 – Telescoping Desk Stand Technology using the Center of Display VESA® Mounting Interface for Flat Panel Monitors

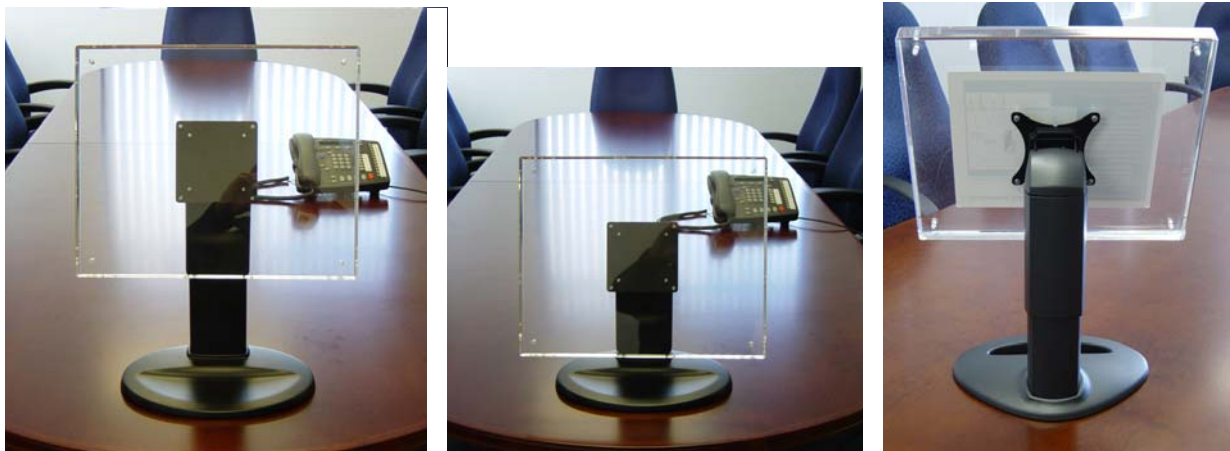

Figure 4 – Design of an Ergonomically Correct Desk Stand for the Average Range of Male and Female Users, Dimensioned from the Floor using Standard Height (737 mm [29"]) Desk Surface

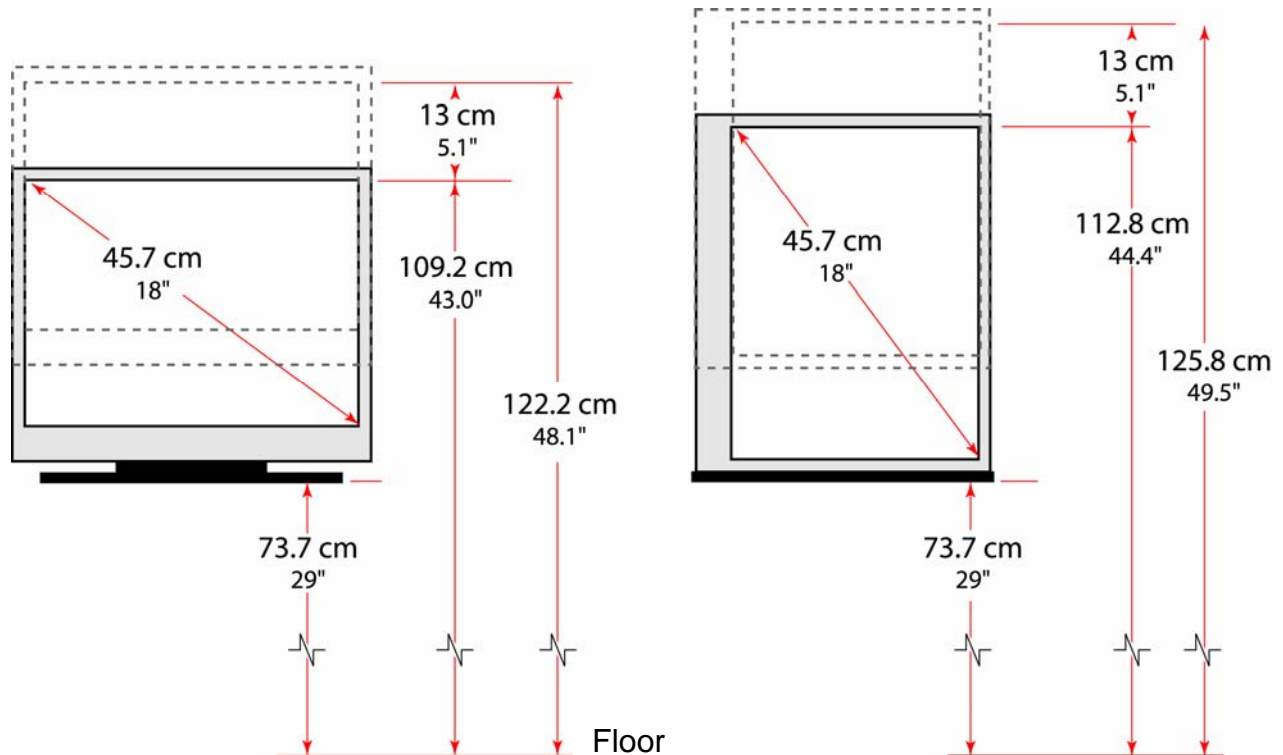

Figure 4 illustrates the design of an ergonomically correct desk stand in both Portrait and Landscape modes based on the anthropometric data shown in Table 1, extended to accommodate world populations (130 mm [5.1"]). This extended range of adjustment allows placing the monitor at sufficient height at the upper range and also allows a bias toward the lower end of travel to optimize viewing in the Portrait mode.

Providing the correct viewing heights for both male and female operators becomes more difficult when the display is used in portrait mode. In many existing height-adjustable stands, to provide clearance for the monitor to rotate, the monitor is placed quite high – too high for most female operators. Addressing this class of operators is extremely important because statistics show that 70% of all Musculo-skeletal Stress Disorders associated with computer use occur in the female population. By providing a full 130 mm (5.1") of vertical adjustment, and placing the range at the appropriate heights, the properly designed stand provides optimum viewing heights for both male and female operators – in both Portrait and Landscape modes.

Figure 5 – Design of an Ergonomically Correct Desk Stand for the Average Range of Male and Female Users, Dimensioned from the Work Surface

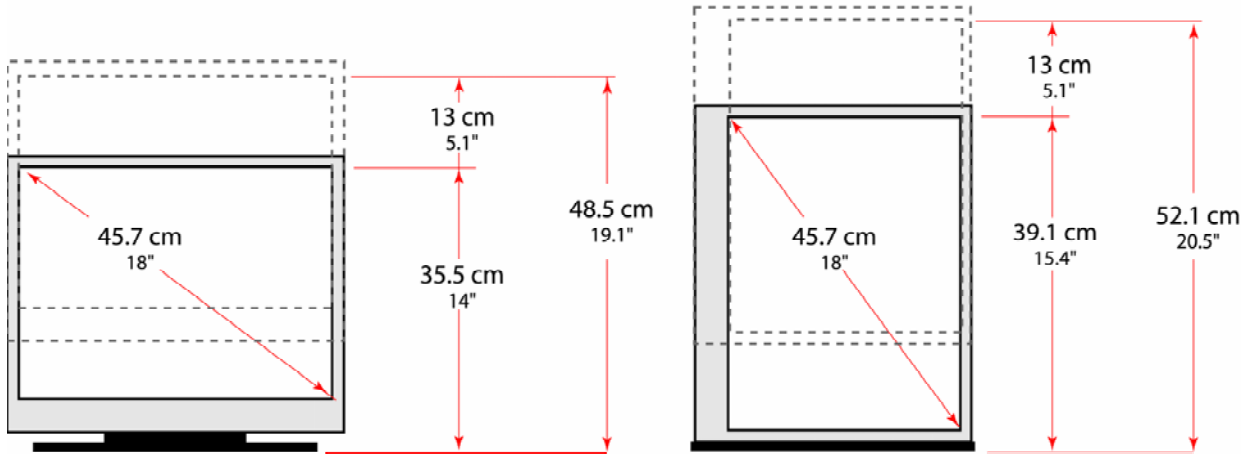
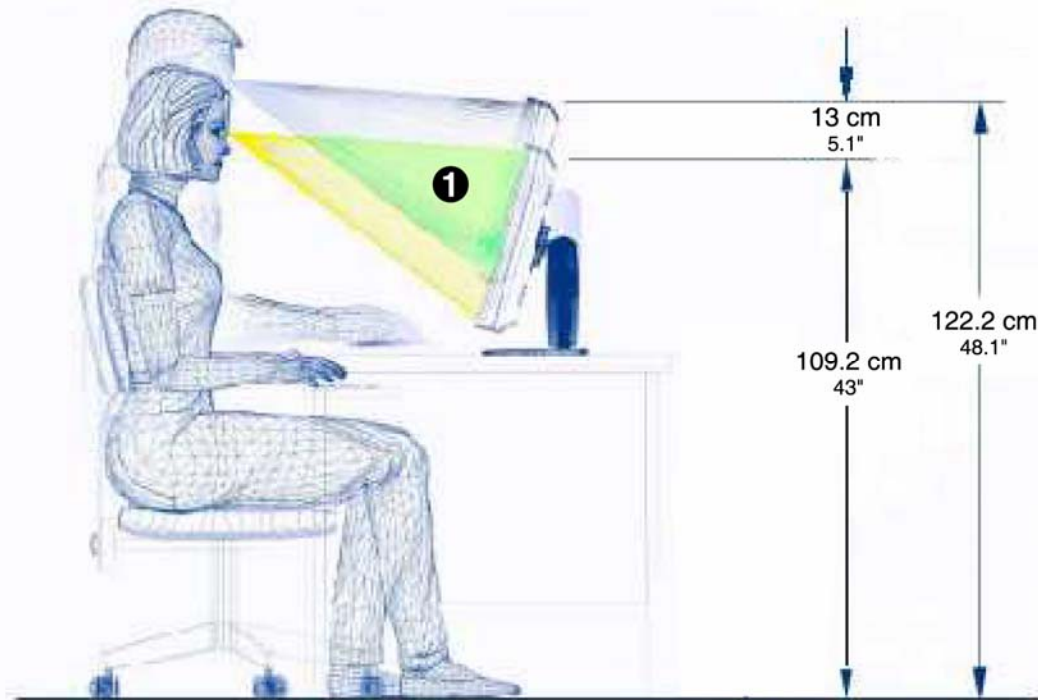

Figure 5 illustrates the stand design shown in Figure 4, dimensioned as a freestanding device. Available anthropometric data indicates that the gender eye height variance for the world’s populations ranges from 11 cm to 13 cm. Accordingly, this design can be utilized for a majority of the world’s populations.

Figure 6 – Side View of a Desk Stand Designed According to the Dimensions Shown in Figures 4 and 5



Note 1: See Appendix A

©2004 Constant Force Technology

Applicability to Entire Range of Operators

The stand described above has been designed to provide the proper range of vertical height adjustability for the **average** range of male to female users. However, with a couple of minor accommodations it can be utilized to provide ergonomically correct eye height viewing for the entire range of 5% female to 95% male users, as follows:

For users who are shorter than average, i.e., 157 cm (62") or shorter:

- Utilize an adjustable chair and quality footrest to raise the eye height of the operator from 25 mm (1") to 100 mm (4") to provide the proper eye height viewing for this class of users. See Table 2.

For users who are taller than average, i.e., 180 cm (71") or taller:

- Raise the monitor and stand on the worksurface from 25 mm (1") to 100 mm (4") to provide the proper eye height viewing for this class of users. See Table 2.

Keyboard Positioning

If the monitor screen is set 25 mm (1") below the operator's eye height as recommended, the center row of the keyboard should be positioned as follows:

- 48.3 cm (19") below the top of the display screen for **shorter than average** users.
- 50.8 cm (20") below the top of the display screen for the **average** range of users
- 53.3 cm (21") below the top of the display screen for **taller than average** users.

Conclusion - Summary

Improving the Human Interface with Flat Panel Monitors

Flat panel monitors are small and lightweight so they have inherent advantages over CRTs in providing an improved user interface, especially in the high stress business/office work environment. Ergonomic studies done years ago indicate that screen positioning is one of the most important factors in providing a comfortable work environment and preventing a broad range of Musculo-skeletal Stress Disorders (MSDs) associated with computer use. Disorders such as eye, neck and back strain, fatigue and wrist, hand, elbow and shoulder diseases such as Carpal Tunnel Syndrome can all be dramatically improved through use of good ergonomic design.

Dynamically adjustable stand and lift system designs should be based upon sound ergonomic ground rules and scientific anthropometric data as outlined above. Flat panel monitor manufacturers and systems integrators and now after-market users can use such devices to provide an optimum human interface for their monitors. **Note:** The science of ergonomics is constantly evolving, therefore all values and recommendations in this paper are provided as guidelines only. Monitor and display manufacturers and end-users are urged to consult with a certified Ergonomist who is familiar with the worldwide anthropometric data and ergonomic standards applicable to computer usage for corroboration of the recommendations made for each application.

Harry C. Sweere
Chairman and Chief Scientist

*Content subject to change without notification.

America Sales & Corporate HQ
St. Paul, MN USA
(800) 888-8458
+1-651-681-7600
www.ergotron.com
sales@ergotron.com

EMEA Sales
Amersfoort, The Netherlands
+31 33 45 45 600
www.ergotron.com
info.eu@ergotron.com

APAC Sales
Singapore
www.ergotron.com
info.apac@ergotron.com

Worldwide OEM Sales
www.ergotron.com
info.oem@ergotron.com



ERGOTRON, INC. NEO-FLEX™ LCD STAND

APPLICATION NOTES

1. The monitor must comply with the Video Electronics Standards Association Flat Display Mounting Interface (FDMI) Standard, Part D (VESA FDMI-D). This interface consists of a 75 mm x 75 mm (3" x 3") or 100 mm x 100 mm (4" x 4") four bolt hole pattern located at the rear, center of the monitor. In many cases the interface is flush with the rear of the monitor or it may be recessed. It also may be covered with a plastic cover and in some cases it is used to mount an existing, non-ergonomic desk stand. **The Neo-Flex Stand will not work if your monitor is not VESA compliant.**
2. The Ergotron Neo-Flex Stand is designed to manage flat panel monitors or LCD TVs ranging in weight from 2.7 kg (6 lbs) to 7.3 kg (16 lbs). In some cases the weight of the monitor can be found by reading the manufacturer's literature. If it is not available, you may weigh the monitor simply by using a bathroom or other scale. If your monitor weighs near the upper or lower weight range, you may wish to obtain a more precise weight measurement by removing the existing base or stand from the monitor. **The Ergotron Neo-Flex Stand will not perform properly if the monitor falls outside of the specified weight range.**
3. The Neo-Flex Stand has been designed to meet the ergonomic eye height requirements for the average range of female to male operators based on a 460 mm (18.1") diagonal monitor with the VESA interface located in the top to bottom centerline of the display.
4. An 18" diagonal monitor is in the center of desktop monitor size range, which ranges from 15" diagonal to 21" diagonal. Because of the difference in screen size between a 15" monitor and a 21" monitor, the stand will provide a different top of screen height for each size of display. This variation will range from approximately 1" below the shown screen height for a 15" D monitor to 1" above the shown screen height for a 21" D display.
5. When choosing a monitor to mount on the stand, it is important to select a monitor where the VESA mounting interface is located in the center of the display as specified in the VESA FDMI standard. If the mounting interface is located either above or below the centerline of the display, the ergonomic heights designed into the stand and shown above may not be achieved.

TECHNICAL SPECIFICATIONS

- | | | |
|-----|--|---|
| 1. | Lift weight capacity of stand: | 2.7 kg (6 lbs) to 7.3 kg (16 lbs), field adjustable |
| 2. | Lift capacity of the stand up/down tilt: | 2.7 kg (6 lbs) to 7.3kg (16 lbs), field adjustable |
| 3. | Vertical height adjustment range: | 130 mm (5.1") |
| 4. | Monitor up/down tilt range: | -5° to +30° |
| 5. | Monitor pan (side-to-side tilt range): | 70° (35° left/35° right) |
| 6. | Portrait/landscape (P/L) rotation range: | 90°, clockwise rotation |
| 7. | Adjustment moving forces (typical): | 1 kg (2.2 lbs) to 2 kg (4.4 lbs) |
| 8. | Field assembly requirements: | Base installation, monitor mount |
| 9. | Tools required for assembly and all adjustments: | #2 Phillips screwdriver
6 mm-7 mm (1/4"-5/16") D shaft |
| 10. | Weight of stand: | 2 kg (4.4 lbs) |
| 11. | Shipping weight: | 2.3 kg (5.1 lbs) |
| 12. | Monitor interface compliance: | VESA FDMI-D 75/100 mm mounting interface |
| 13. | Warranty: | Three years from date of purchase |

APPENDIX B

Optimum Neutral Posture for Seated Computer Operators

HEAD Directly over shoulders, without straining forward or backward, about an arm's length from screen.

NECK Elongated and relaxed.

SHOULDERS Kept down with the chest open and wide.

BACK Upright or inclined slightly forward from the hips. Maintain the slight natural curve of the lower back.

ELBOWS Relaxed, at about a 90° to 120° angle.

WRISTS Relaxed and in a neutral position, without flexing up or down.

KNEES Slightly lower than the hips.

ADJUSTABLE CHAIR Sloped slightly forward to facilitate proper knee position.

SCREEN At eye level or slightly lower.

FINGERS Gently curved.

KEYBOARD Best when kept flat or at slight negative tilt (for proper wrist positioning) and at or just below elbow level. Computer keys that are far away should be reached by moving the entire arm, starting from the shoulders, rather than by twisting the wrists or straining the fingers. Take frequent rest breaks.

FEET Firmly planted on the floor. Shorter people may need a footrest.

